

Technical Evaluation of Selexol-Based CO₂ Capture Process for a Cement Plant

D. Y. Tsunatu^{1*}, I. A. Mohammed-Dabo² and S. M. Waziri²

¹Chemistry Department, Taraba State University, Jalingo, Taraba, Nigeria.

²Chemical Engineering Department, Ahmadu Bello University, Zaria, Kaduna, Nigeria.

Authors' contributions

This work was carried out in collaboration between all authors. Author DYT designed the study, ran the model and simulation for all cases, performed the data analysis, and reviewed the manuscript. Author IAM-D supervised the model ran and the data analyses and wrote and revised the manuscript. Author SMW provided valuable suggestions for the study design, interpreted the model results and revised the manuscript. All authors read and approved the final manuscript.

Article Information

DOI: 10.9734/BJECC/2015/12482

Original Research Article

Received 1st July 2014
Accepted 4th February 2015
Published 17th April 2015

ABSTRACT

Cement industry accounts for the second largest emitter of anthropogenic greenhouse gas in the globe with 900 kg CO₂ emitted into the atmosphere from producing one tonne of cement. Hence, the effort made to mitigate this issue seems not productive, which gives rise to the design of the carbon capture and sequestration [CCS] process which is one of the few ways obtained to greatly reduce CO₂ production from the cement plant. The research work assessed the technology used for the cement plant by employing an old cement plant with post-combustion CO₂ capture using physical solvent (Selexol). The Aspen Hysys simulation results show that the process can capture 97% of the CO₂ and lean loading of 0.37. The Ashaka Cement Plant operates at maximum capacity of approx. 1 million tonnes cement /year with CO₂ released at about 500,000 tonnes per year. The capture unit was able to reduce the CO₂ released into the atmosphere from 4.86% to 0.13%. The overall result of the analysis shows that selexol has proven to be thermally and chemically stable under the operating conditions used. It is recommended that, the simulation results should be retrofitted into the Ashaka cement plant, in order to determine the best CO₂ capture efficiency, performance which results to the choice of this capture technology.

Keywords: Carbon capture; greenhouse gas emission; selexol; aspen hysys; cement plant.

*Corresponding author: Email: tsunatu.danlami@yahoo.co.uk;

1. INTRODUCTION

The Earth's climate depends on the functioning of a natural "greenhouse effect." This effect results from heat-trapping gases (greenhouse gases) such as methane, water vapour, carbon dioxide, ozone, and nitrous oxide which absorb heat radiated from the Earth's surface and lower atmosphere and then radiate much of the energy back towards the Earth surface. Carbon dioxide concentration in the atmosphere has been the principal factor causing global warming over the past 50 years. Hence, leading to its build-up concentration on the Earth since the industrial era around the mid-1700s, and this is as a result of burning fossil fuels (coal, oil, and natural gas) and biomass burning [1,2,3]. These emissions are thickening the blanket of heat-trapping gases in the Earth's atmosphere, causing its surface temperature to rise.

Sources of carbon dioxide include:

- Fossil fuel combustion which accounts for 65% CO₂
- Deforestation (CO₂ released from trees that are cut and burned or left to decay) accounts for 33%, and
- By-products of cement production account for the remaining 2%.

From the above, CO₂ concentrations worldwide have increased to approximately 365 ppm (0.0365%). The increase seems trivial, but it also means that about 3 billion metric tons (3 gigatons) of CO₂ are being added to the atmosphere yearly; hence as a serious greenhouse gas, result of its increase should equally increase the Earth's temperature as well.

The International Energy Agency (IEA) estimated that, to have a 50% reduction in global CO₂ emissions by 2050 (which is widely believed to be equivalent to reducing the increase in global temperature by 2 degrees), Carbon Capture and Sequestration (CCS) will definitely contribute to nearly one-fifth of emissions reductions, across both the power and industrial sectors.

By 2050, as estimated by IEA, the cost of reducing climate change without CCS could be around 70% higher than with CCS. Already it will be around 40% by 2030 as estimated.

Therefore, CCS is currently the only option for decarbonizing the steel, chemical and cement industries. This process has been reported to

having the ability of reducing annual carbon dioxide emissions by 9 – 16 billion tonnes worldwide by 2050 [4].

Cement industry has been one of the world's largest industrial sources of CO₂ emissions accounts for about 1.8 Gt/year in recent years [5]. Improved energy efficiency, replacing fossil fuels with wastes which may be regarded as 'carbon neutral', increasing the cement: clinker ratio by increasing the use of additives, and use of biomass have been over the years, the substantial means of reducing CO₂ emissions per tonne of cement in the cement industry. The scope for further reductions by these means has become limited, yet there is an increasing need to reduce this emission to avoid any further increase in the contribution to anthropogenic climate change.

This brings about a good opportunity in the cement industry for CCS, because cement plants are relatively large point sources of CO₂ with the concentration of CO₂ in cement plant flue gas being relatively high and over 60% of total CO₂ emissions from a modern cement plant are from mineral decomposition where the resulting CO₂ emission cannot be avoided by use of any alternative energy source [6,7]. This technology enables significant reduction in CO₂ emission which could also lead to reduction of other pollutants such as SO_x, NO_x and particulate matters.

Cement production is both energy and emissions intensive: 60–130 kg of fuel and 110 kWh of electricity are required to produce a ton of cement, leading to emissions of around 900 kg CO₂/t [8]. The production of cement releases greenhouse gas emissions both directly and indirectly: the heating of limestone releases CO₂ directly, while the burning of fossil fuels to heat the kiln indirectly results in CO₂ emissions. The direct emissions of cement occur through a chemical process called *calcination*. Calcination occurs when limestone, which is made of calcium carbonate, is heated, breaking down into calcium oxide and CO₂. This process accounts for ≈50% of all emissions from cement production [9,10]. Indirect emissions are produced by burning fossil fuels to heat the kiln. Kilns are usually heated by coal, natural gas, or oil, and the combustion of these fuels produces additional CO₂ emissions, just as they would in producing electricity. This represents around 40% of cement emissions. Finally, the electricity used to power additional plant machinery, and the final transportation of

cement, represents another source of indirect emissions and account for 5-10% of the industry's emissions [11].

This paper describes the technical assessment of employing post-combustion CO₂ capture system of a typical cement plant located in Nigeria. The research work is aimed at developing a simulation – based tool for CO₂ capture of a cement plant using a physical solvent. The research work is limited to the design of CO₂ capture process for flue gas from Ashaka Cement Plant with focus on Selexol-Based CO₂ capture process flue gas analysis and designing the Selexol capture process using Aspen Hysys™.

2. METHODOLOGY

2.1 Base Cement Plant System

Ashaka Cement Company Plc located in Bajoga, Gombe State-Subsidiary of global cement giant – Lafarge was chosen for this research work. The plant has an operating capacity of up to 850, 000 tons of cement a year. It uses limestone obtained from Ashaka, Bajoga and Bage in Funakaye L.G.A as the main feedstock and Coal (Lignite) from Maiganga Village (Akko L.G.A) as the main source of energy generation. The plant runs on full capacity for the whole year with turnaround maintenance carried out once a year. The life span of the plant was assumed to be 20 years. The design parameters and emissions of the plant are represented in Tables 1 and 2 respectively. The regulated limit of NO_x and SO_x emissions from typical cement plants in Nigeria are 2.42kg/ton and 0.046 kg/ton respectively. The plant emits approximately 500,000 tons of CO₂ per annum. Approximately 56% of the CO₂ comes from the calcination of limestone, and the rest from the combustion of the coal and electricity use. A process flow diagram for the calcination process or cement clinker burning process for the plant is shown in Fig. 1.

2.2 Process Design for the Capture System using Aspen Hysys

Flue gas from Ashaka Cement Plant is usually emitted through the stack into the atmosphere at a temperature of 180°C. The flue gas prior to emission is passed through the Gas Conditioning Tower (NIRO) where most of the SO₂ is scrubbed and all particulate matters are removed. The flue gas is further send to the Bag

Filter House where the remaining particulate matters especially dust are trapped. Hence, a clean flue gas, with low SO₂ and particulate concentrations is therefore used as the basis for the Selexol-Based CO₂ Capture Process, as shown in Fig. 3 simulated using Aspen Hysys™. The CO₂ capture plant was designed to remove 97% of the CO₂ from flue gas stream coming from the flue stack of the cement plant. The flue gas goes through the cooler to be cooled to 40°C from 180°C. The flue gas leaves the cooler 1 with a pressure and temperature of 100kPa and 40°C which is the appropriate for the absorber's performance. The flue gas from the cooler 1 enters the bottom of the absorber and the lean Selexol (33.4 wt. %) with a CO₂ loading of 0.37 mole CO₂/mole Selexol enters from the top of the column counter-currently at a pressure of 100 kPa and 27.99°C. It is very important to keep the lean Selexol solution temperature as low as possible for two crucial reasons: (i) to reduce Selexol and water make – up and (ii) to increase the CO₂ capture efficiency. The number of stages for the absorber obtained in this research is 10, to achieve a rich Selexol-CO₂ loading of 0.4 mole CO₂/mole Selexol and 97% recovery. Clean gas from the top of the absorber is now released into the atmosphere since it has now met the standard limits set by World Bank and USEPA as shown in Table 3. The absorber operates at a temperature of 50°C and a pressure of 2360 kPa. This pressure enhances the absorption rate because from Henry's law of CO₂ solubility in physical solvents shows that as the partial pressure of the gas increases, absorption also increases, which made the absorber pressure to be set at ≈ 2360 kPa. The entire process within the absorber is an exothermic process where Selexol reacts physically with CO₂ in the column. This interaction between the solvent and gas forms a weak bond between the compounds at higher pressure which can be regenerated physically by reduction in pressure within Flash Tanks in series so that the CO₂ would be released. The rich Selexol from the bottom of the absorber goes to the rich Selexol valve to reduce the pressure from 2403 kPa to 1800 kPa. The rich Selexol then flows into the GASFLASH where it is separated into vapour and liquid phases, with the vapour containing about 0.9980 mol-fraction of CO₂ while the rich Selexol flows from the bottom to VALVE2 where the pressure is further reduced from 1800 kPa to 980.7 kPa. This continues till the rich Selexol finally enters LP FLASH where it operates at 98.07 kPa (≈ atmospheric pressure) to release virtually all

the CO₂ absorbed within the rich Selexol. The separation in this Low Pressure Flash Tank composed of about 0.9814 mol-fraction of CO₂ which is then compressed in COMPRES2 to increase the pressure from atmospheric to 1961 kPa which meet with other CO₂ streams coming from FLASHGAS1 and COMPGAS2 for onward separation of liquid traces in a separation tank to allow CO₂ captured or produced to be compressed depending on its utilization. This research made provision for the CO₂ to be compressed to a pressure of 1800 kPa and temperature of 179.7°C for the pipeline transportation which is out of the scope for this study. Type and amount of packing are selected so that the maximum recovery is obtained using the minimum consumption of the solvent - Selexol. After the simulation, product recoveries from the simulation process were 97%. This shows that, the CO₂ emission of the plant was reduced from 4.86% to 0.1288% as shown in Table 2.

3. RESULTS AND DISCUSSION

The results presented in this research are obtained from Data Generated (DG) and Simulation Results (SR). These results originate from the flue gas analysis to the technical aspect of the simulation using Aspen Hysys.

Fig. 2 shows the daily CO₂ concentration emitted for the cement plant during the period of the flue gas analysis (July, 2013). From the chart, it could be observed that, the plant's emission of CO₂ is between the range of 87,398 to 87,480 mg/m³ with a sharp decline between day 20 and 22 signifying possible change in quantity of fuel and limestone used in the kiln. The result obtained for the period under review was plotted against World Standards (Permissible Limits, 811.7mg/m³), and it was found that, Ashaka Cement Plant emits far above the world standard i.e. emitting 87480 mg/m³ resulting to approximately 10677.4% deviation from the World Standards.

It is seen from Fig. 4 that the lean solvent flow rate remains constant with lowering the number of stages required for the separation. This is common with physical absorption unlike chemical absorption which involves increase in flow rate of the solvent with lowering the number of stages.

Fig. 5 shows the variation in L/G in absorber with lean loading for flue gas from Ashaka Cement plant. L/G is the ratio of the total molar liquid flow to the total molar gas flow in the column. The

absorber was simulated with 10 equilibrium stages and three Flash Tanks operating at equilibrium for the solvent regeneration. The required Selexol flow rate increases as the lean loading increases since with increasing lean loading, the capacity of the solvent for CO₂ absorption increases. As can be seen from the figure, beyond a certain lean loading, there is a sharp decrease in the liquid flow rate required to achieve the 97% CO₂ capture.

Table 1. Ashaka cement plant flue gas analysis data for process simulation using aspen hysys

Parameters	Kiln operating at highest capacity
Temperature (°C)	180
Pressure (Bar)	1
Mole Flow (kmol/hr)	1210.26
Mass Flow (kg/hr)	53,243.55
Volume Flow (m ³ /hr)	252,000
Mass Flow, kg/hr:	
CO ₂	52,999.659
SO ₂	2.588
NO ₂	191.372
O ₂	49.930
Mole Flow, kmol/hr:	
CO ₂	1204.5
SO ₂	0.0404
NO ₂	4.1603
O ₂	1.5603
Mass Fraction:	
CO ₂	0.99540
SO ₂	0.00005
NO ₂	0.00359
O ₂	0.00094
Mole Fraction:	
CO ₂	0.99520
SO ₂	0.00003
NO ₂	0.00344
O ₂	0.00129

As the temperature of absorption decreases, the driving force for physical absorption increases. Hence, the temperature of the solvent does not have a significant effect on the performance of the system. This is mainly because the solvent has a low specific heat and it takes up the heat of absorption quickly. This causes the temperature of the Selexol to rise upon interaction with CO₂ and negates the effect of having lower solvent temperature. The absorber tends to exhibit a temperature bulge at the top of the column (i.e. Stage 1). There is a significant amount of interaction at the top of the column when the lean liquid enters. Due to the highly exothermic nature

KILN TYPE: GEPOL PREHEATER
 PLANETARY COOLER 9
 POWER: 488kw/h
 MAX. SPEED: 3rpm
 NOMINAL CAPACITY: 60tph
 DIMENSION: 72m by 4m

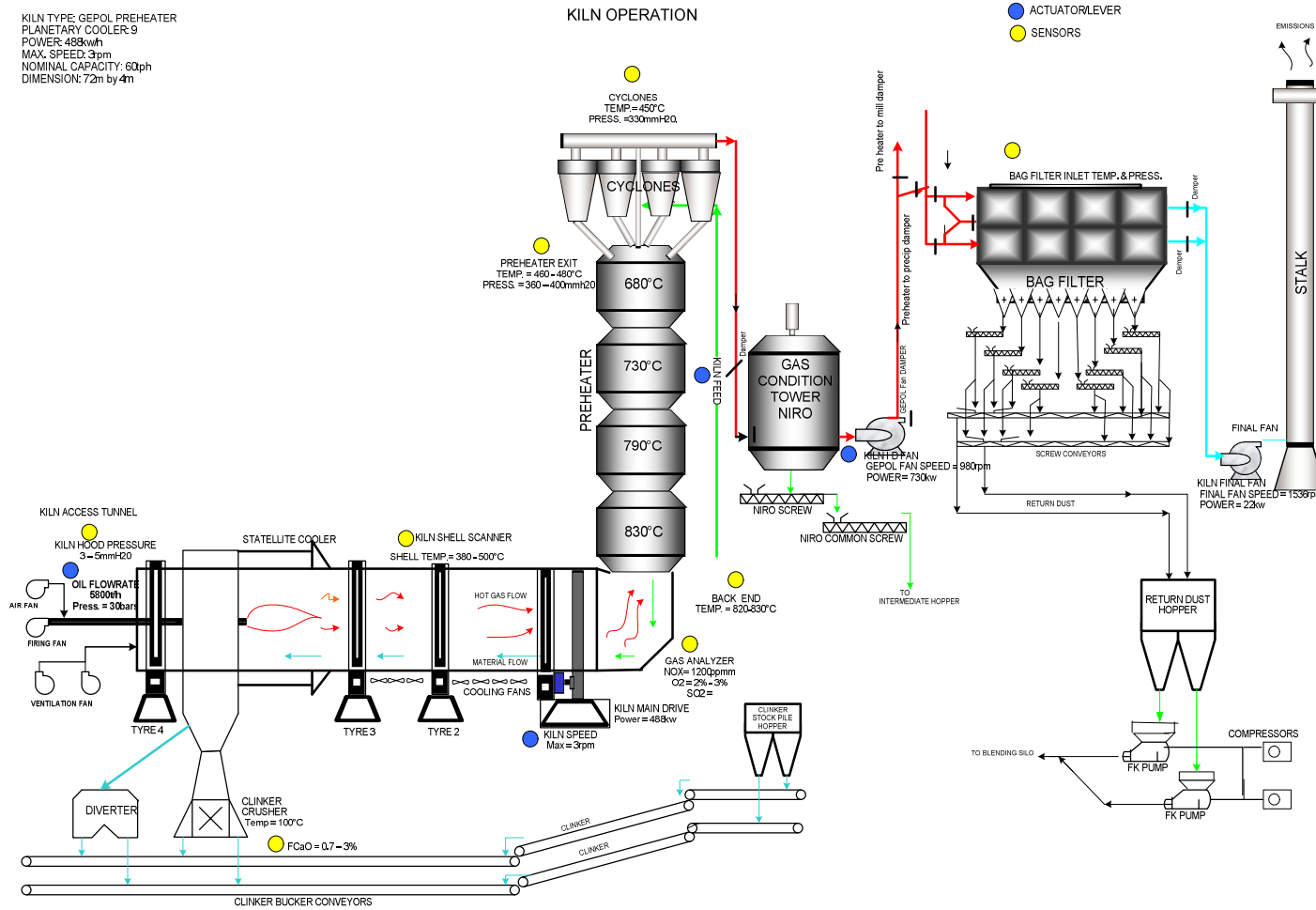

Fig. 1. Ashaka cement plant kiln operation

of the reaction, a lot of heat is released. The liquid takes up this heat and since the liquid has low specific heat, its temperature rises. This causes the bulge at the top of the column. As the liquid proceeds down the column, it exchanges heat with the gas and hence gets cooled. Fig. 6 shows the temperature profiles in the absorber for the liquid for Ashaka Cement flue gas.

Table 2. Flue gas analysis of Ashaka cement plant (July, 2013)

Parameters	Fan inlet (Stack inlet)	Stack exit
Gas Temperature (°C)	35.2	38.4
Ambient Temperature (°C)	29.6	34.9
O ₂ (%)	16.66 (166,600 ppm)	14.36 (143,600ppm)
CO ₂ (%)	3.15 (31,500ppm)	4.86 (48,600ppm)
CO (ppm)	0	0
Stack Loss (%)	0.9	0.4
η- Efficiency (%)	99.1	99.6
Dew Point (°C)	20.30	27.5
λ- Lanbda	4.87	3.16

Source: Field work by researchers, 2013

Table 3. Concentration of the components present in the clean gas released into the atmosphere

Components	Conc. in flue gas before absorption (%)	Conc. in clean gas stream (%)
CO ₂	4.86	0.1288
SO ₂	0.2629	0.0000
O ₂	94.7426	99.8697
NO ₂	0.1283	0.0005
Selexol	0.0000	0.0000
H ₂ O	0.0062	0.0010

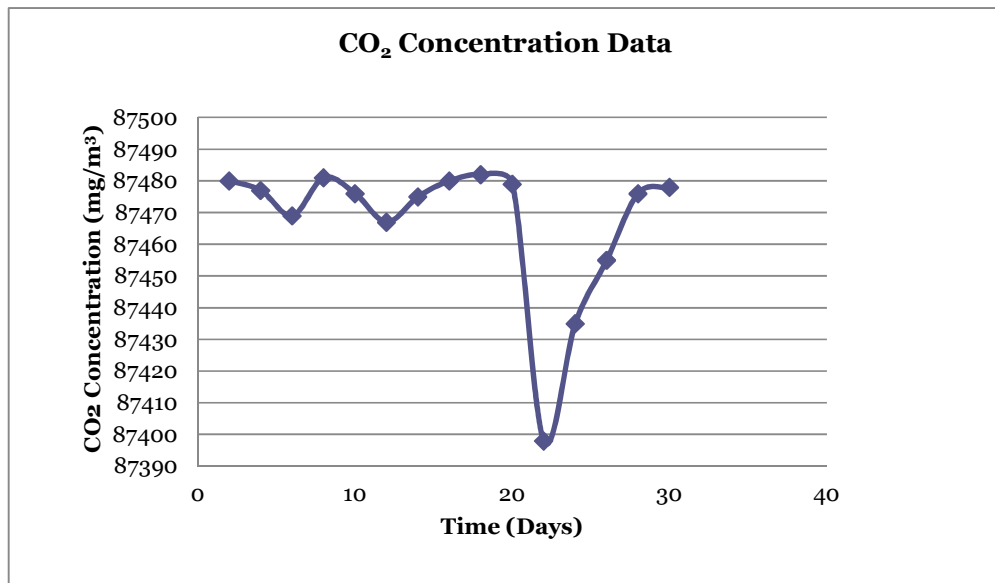

Fig. 2. CO₂ Concentration data of Ashaka cement plant

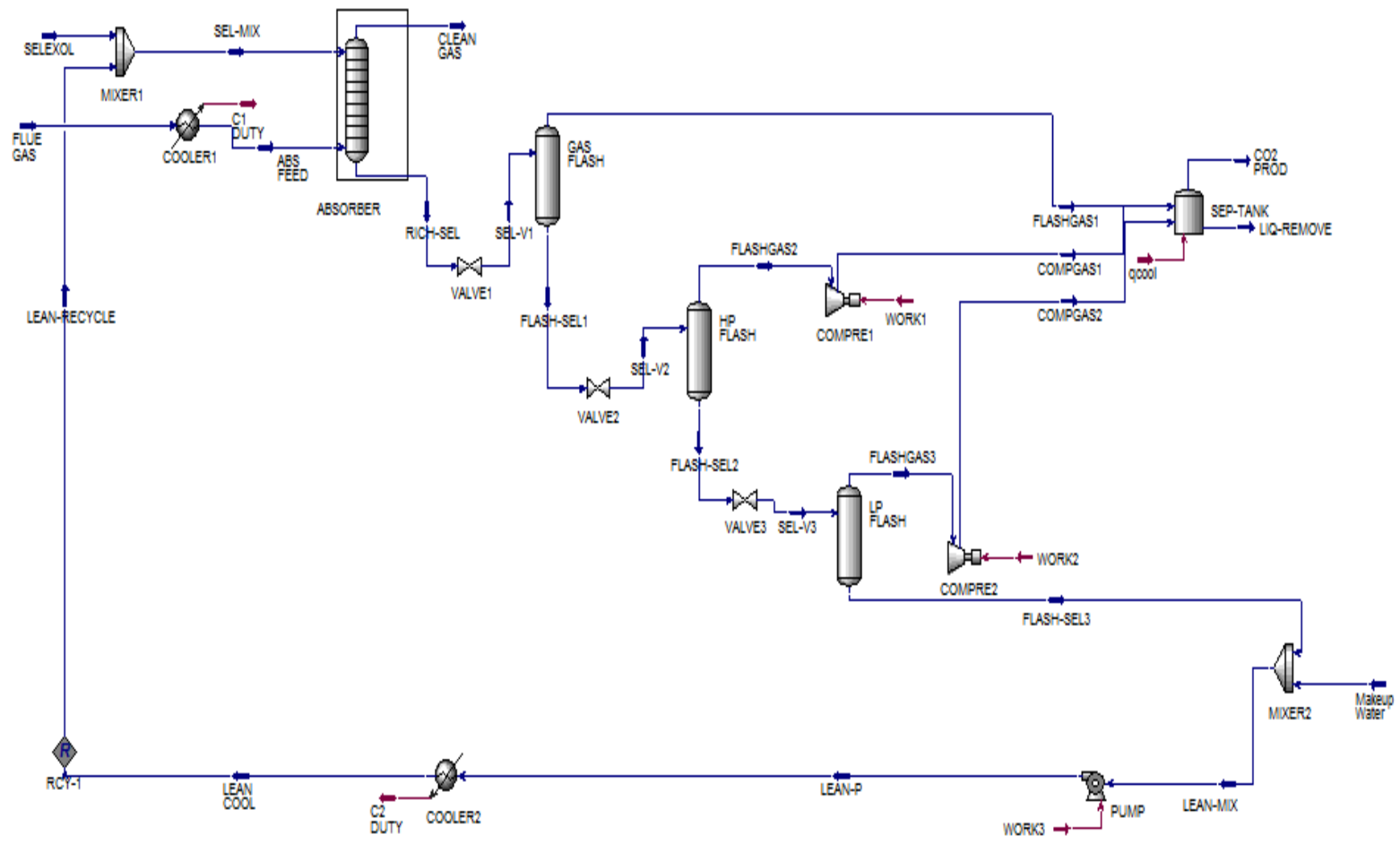

Fig. 3. Aspen Hysys simulation process flow diagram for the Selexol capture unit for Ashaka cement plant

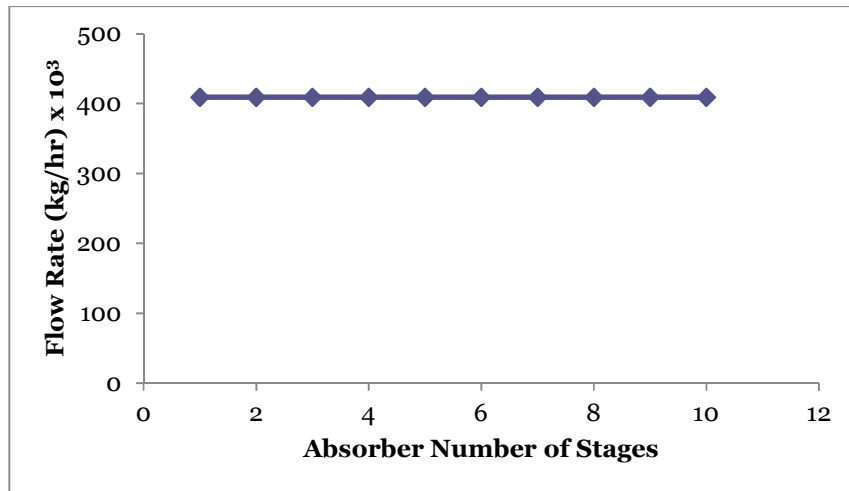

Fig. 4. Lean selexol flow rate for the absorber number of stages

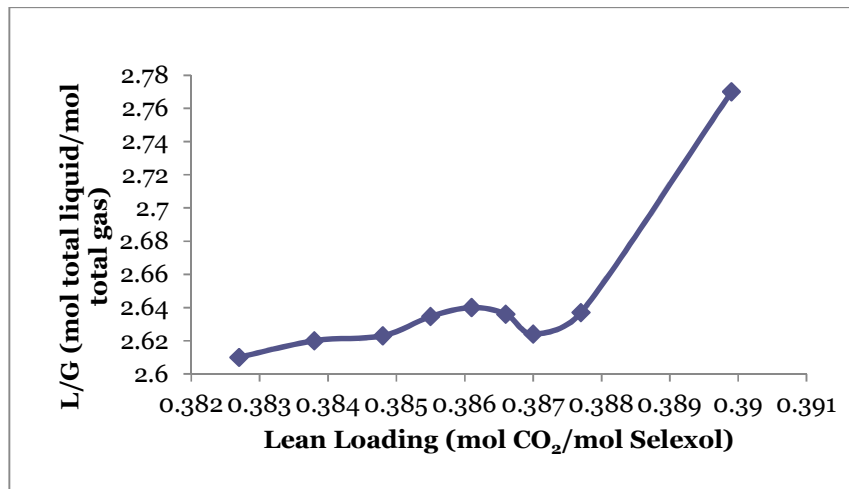

Fig. 5. Variation of L/G with lean loading for 97% CO₂ capture from Ashaka

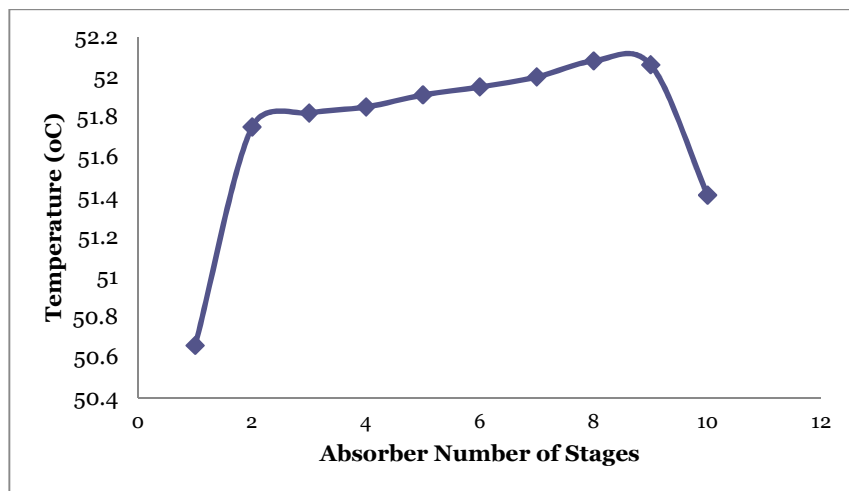

Fig. 6. Temperature profile across the absorber number of stages

The enthalpy change due to solute and solvent interactions in the liquid phase is defined as heat of mixing and more specifically it can be defined as the enthalpy change when pure species are mixed to form 1 mole of solution. The heat of mixing is negative for the strong solute-solvent interaction which indicates exothermic reaction of the system. Negative values for ΔH suggest that the mixing is exothermic and the interaction between the gaseous solute and the solvent is strongly ideal. The calculated property for Selexol-CO₂ system is presented in Fig. 7. The maximum enthalpy for the mixing of CO₂ in Selexol occurred at $x_{CO_2} = 0.39$ with a value of $-216.2 \text{ kJ/molCO}_2$ at 50.66°C .

The performance of a physical solvent can be predicted by its solubility. The solubility of an individual gas follows the Henry's law-the solubility of a compound in the solvent is directly proportional to its partial pressure in the gas phase. Selexol is a physical solvent. Therefore, the performance of the Selexol process enhances with increasing CO₂ partial pressures. As shown in Fig. 8, the solubility of CO₂ in physical solvents (Selexol) increases linearly with its partial pressure. Chemical solvents have a higher absorption capacity at relatively low acid gas partial pressures. However, their absorption capacities plateau at higher partial pressures. Therefore, chemical solvent technologies are favourable at low acid gas partial pressures and

physical solvents are favoured at high CO₂ partial pressures. This was the case for this process. Physical solvents are more efficient to regenerate, a second advantage for high acid gas partial pressure applications. The physical absorption allows for the solvent to be partially regenerated by pressure reduction, which reduces the energy requirement compared to chemical solvents.

The effect of inlet flue gas temperature on the CO₂ removal across the column was studied, it was observed that as the temperature increases the capture rate decreases. This is evidenced that at higher temperature, physical solvent performance decreases as shown in Fig. 9. The flow sheet represents a continuous absorption/regeneration cycling process with a 97% recovery of the CO₂ at 0.37 lean loading.

The pressure in the absorber has a significant effect on the performance of the process. The pressure increase in the column is a favourable condition for the absorption of the CO₂ by Selexol solvent. As can be seen, that the pressure increases from the top of the column to the bottom yields an adequate pressure drop of 0.0545 bars, this small pressure drop drives the gas flow upward. This also helps abate flooding within the column. Fig. 10 shows how pressure is distributed across the number of HETP (packing) within the column.

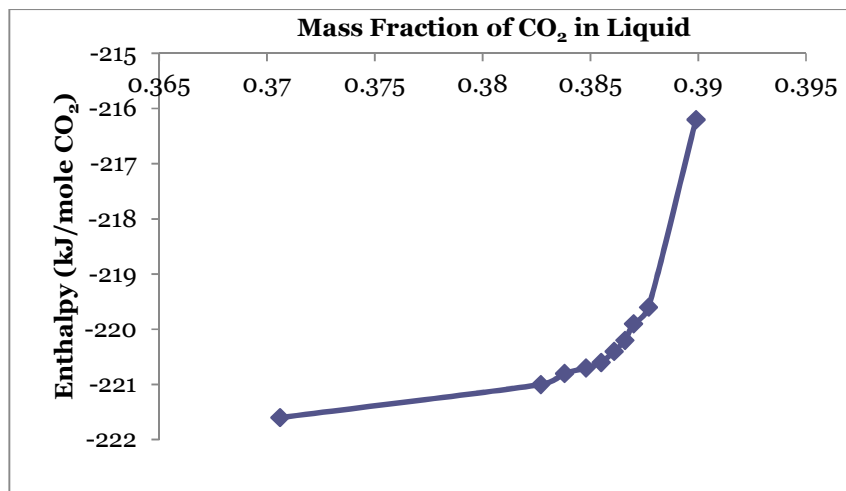

Fig. 7. Enthalpy for the solubility of CO₂ in selexol for the absorber stages

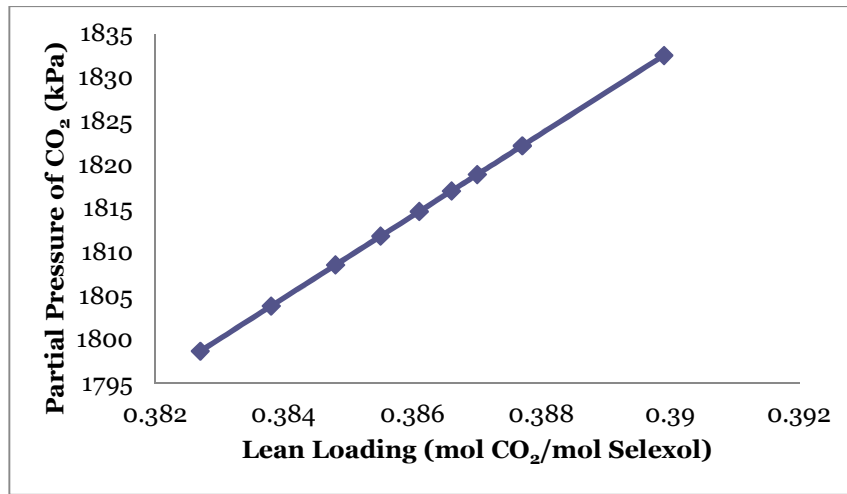

Fig. 8. Solubility Profile of CO₂ in Selexol for the Absorber

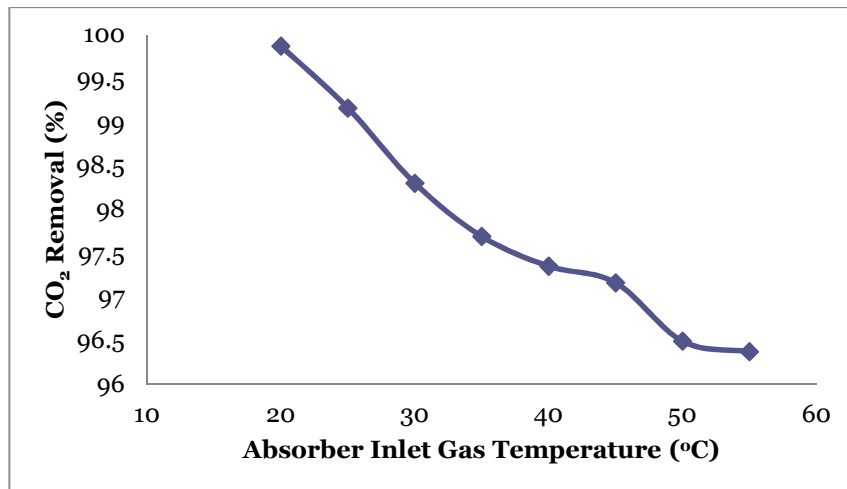

Fig. 9. Effect of inlet gas temperature on CO₂ removal across the column

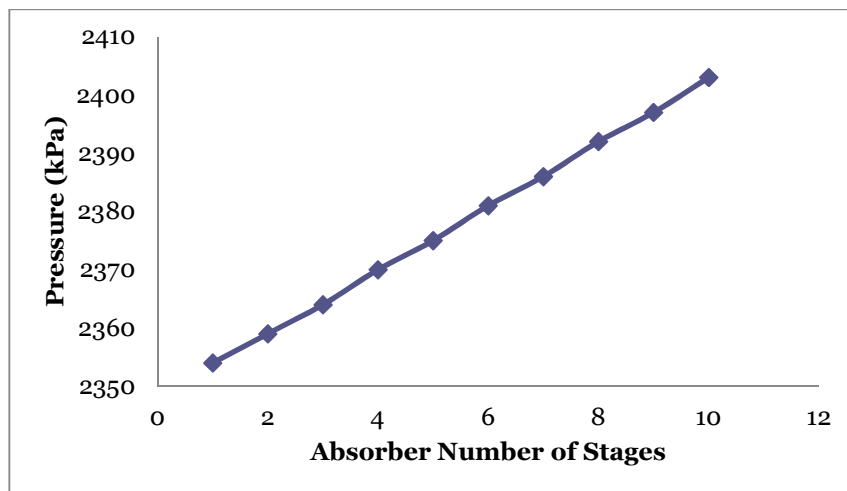

Fig. 10. Pressure profile across the absorber number of stages

4. CONCLUSION

From the simulation results obtained in this study, it would be concluded that, the concentration of CO₂ in the cement plant flue gas was above 35%, hence making Post-Combustion Capture more favourable, which makes design of the Selexol-Based CO₂ Capture Unit for Ashaka Cement Plant to be simulated using Aspen Hysys. The Product Recovery of 97% was obtained as against 90-95% of MEA solvent, with 98% purity of the products. Increase in the number of stages and Selexol loading rate enhances the CO₂ absorption rate while increase in absorption temperature decreases the absorption rate as seen in this research. CO₂ released was reduced from 4.86% to 0.13% compared to world standard (0.05%) with the partial pressure of CO₂ being high in the process, ($\approx 1832\text{kPa}$), hence favouring the performance of physical solvent (Selexol). Finally, the absorber design specification yields approximately 6m in height and 2m diameter compared to MEA absorber specification of approximately 15m height and 6m diameter; hence reduces capital cost required for the CO₂ capture process.

ACKNOWLEDGEMENTS

The researchers wish to acknowledge the management of Ashaka Cement Company Plc, Gombe for granting them the opportunity to use their plant for our research work and the Chemical Engineering Department, A.B.U. Zaria, TetFund Abuja, DSK Foundation, Wukari – Taraba State and Federal Scholarship Board, Abuja for the technical and funding they have provided that has aided greatly in the completion of this research.

COMPETING INTERESTS

Authors have declared that no competing interests exist.

REFERENCES

1. Forster P, Ramaswamy V, Artaxo P, Benten T, Betts R, Faley DW, Haywood J, Lean J, Lowe DC, Myhre G, Nganga J, Prinn R, Raga G, Schulz M, Van Dorland R. Changes in atmospheric constituents and in radiative forcing. In: Climate Change 2007: The Physical Basis, Contribution of working group I to the Fourth Assessment Report of the Intergovernmental Panel on Climate Change [Solomon S, D.Q in, Manning M, Chen Z, Marquis M, Averyt KB, Tignor M, Miller HL. (eds.)] Cambridge University Press. Cambridge, U.K. and New York. 2007;129-234.
2. Thomas RK, Jerry MM, Thomas CP. Global climate change impacts in the United States (eds). Cambridge University Press, U.S.A-New York. 2009;12-46.
3. Thompson DWJ, Solomon S. Interpretation of recent Southern Hemisphere Climate Change. *Science*. 2002;296(5569):895–999.
4. IEA WPF. (2005): Challenges for Large-Scale CO₂ Utilization and Sequestration. IEA Working Party on Fossil Fuels, Task Force on Zero Emissions Technology Strategy, Washington DC; 2012.
5. IEA. Tracking Industrial Energy Efficiency and CO₂ Emissions, OECD/IEA, Paris, France; 2007.
6. Barker DJ, Turner SA, Napier – Moore PA, Clark M, Davison JE. CO₂ Capture in the Cement Industry. *Energy Procedia* 1, GHGT – 9, Elsevier; Science Direct. 2007; 87-94.
7. Jekwu I. Accessing the future of Nigeria's economy: Ignored threats from the global climate change debacle. Developing World Built Environment Research Unit, De Montfort University, Leicester U.K; 2010.
8. Ba-Shammakh M, Caruso H, Elkamel A, Croiset E, Douglas PL. Analysis and optimization of carbon dioxide emission mitigation options in the cement industry. *American Journal of Environment Sciences*. 2008;4(5):482–490.
9. Rubenstein M. Emission from the Cement Industry. The Global Network for Climate Solutions (GNCS FACTSHEETS). The Earth Institute, Columbia University; 2012.
10. Rubin ES, Rao AB. A Technical, economic and environmental assessment of amine – based CO₂ capture technology for power plant greenhouse gas control. Annual Technical Progress Report. U.S Department of Energy/Control for Energy and Environmental Studies, Carnegie Mellon University, Pittsburgh; 2002.

11. WRI. Navigating the numbers: climate policy. World Resource Institute. Greenhouse gas data and international 2005;72–74.

© 2015 Tsunatu et al.; This is an Open Access article distributed under the terms of the Creative Commons Attribution License (<http://creativecommons.org/licenses/by/4.0>), which permits unrestricted use, distribution, and reproduction in any medium, provided the original work is properly cited.

Peer-review history:
The peer review history for this paper can be accessed here:
<http://www.sciencedomain.org/review-history.php?iid=1109&id=10&aid=8859>